

LIVI/N

Automation for residential sliding gates
up to 900 kg



For residential usage



Available in
230V and 24V



#fastasyoulike!
Standard or fast speed
motors (16 m/min for art.
LIVI 6/24N BOOST)



Control board positioned in a lifted position at the front. Always accessible and perfect for small or narrow spaces.



Battery kit with dedicated support (optional and only for 24V models), to guarantee operation during power outages



To program this engine with the DE@Installer app, the NET-NODE interface device must be used.

NET-NODE has its own specific housing inside the motor and allows the smart device to communicate with the control unit.

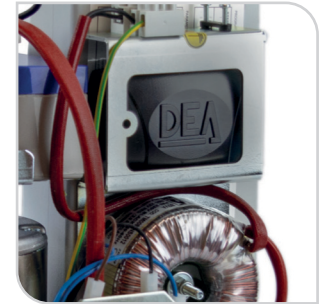

Models available with magnetic limit switches

The fixing system with invisible plate and threaded bar guarantees a quick and compact installation

Compatible with external cable release (item 450N and item BLINDOS - optional), to always have safe access from outside the property



The DE@NET universal control board make this operator compatible with NETLINK System.

D p. 11



NETCOM

Compatible with NETCOM, the device for installation maintenance and remote control management!



LIVI/N	Opening speed	10 m/min
LIVI/N-BOOST		16 m/min

Note: the opening speed could decrease according to the installation characteristics



Models

230V ~ operators with control board, limit switches and encoder



COD.	Art.	EN	kg	⚙️	DEA	EN CODER	OTHER CHARACTERISTICS
614700	LIVI 6N	EN 12453 EN 12449	600 kg	*	NET230N	Z	<ul style="list-style-type: none"> Irreversible with limit switches (magnetic only for 6N/M and 9N/M versions) Speed adjustment and slow down in opening and closing Motor control by encoder and obstacle detection Anti-crushing safety device
614701	LIVI 6N/M	EN 12453 EN 12449	600 kg	*	NET230N	Z	
615700	LIVI 9N	EN 12453 EN 12449	900 kg	*	NET230N	Z	
615701	LIVI 9N/M	EN 12453 EN 12449	900 kg	*	NET230N	Z	

All models have: control board and fixing plate (to be screwed) included

24V ☐ operators with control board and limit switches



COD.	Art.	EN	kg	⚙️	DEA	OTHER CHARACTERISTICS
614750	LIVI 6/24N/F	EN 12453 EN 12449	600 kg	*	NET24N	<ul style="list-style-type: none"> Irreversible with limit switches (magnetic only for 6/24N/M, 6/24N/M-BOOST and 9/24N/M versions) Speed adjustment and slow down in opening and closing Anti-crushing safety device Versions with increased speed only in BOOST models (16m/min)
614752	LIVI 6/24N/M	EN 12453 EN 12449	600 kg	*	NET24N	
614751	LIVI 6/24N/F-BOOST	EN 12453 EN 12449	600 kg	*	NET24N	
614753	LIVI 6/24N/M-BOOST	EN 12453 EN 12449	600 kg	*	NET24N	
615750	LIVI 9/24N/F	EN 12453 EN 12449	900 kg	*	NET24N	
615751	LIVI 9/24N/M	EN 12453 EN 12449	900 kg	*	NET24N	

All models have: control board and fixing plate (to be screwed) included

212E 230V ~ operators with control board and limit switches



COD.	Art.	kg	⚙️	DEA	OTHER CHARACTERISTICS
614702*	LIVI 403N*	400 kg	*	212E	<ul style="list-style-type: none"> ATTENTION: not compatible with NETLINK Self-locking with limit switches Electronic force adjustment Automatic working time learning Controlled input for external safety device
615702*	LIVI 803N*	800 kg	*	212E	

All models have: fixing plate (to be screwed) included

* In order to respect the limit of impact forces foreseen by EN 12453, you must use the external safety devices in compliance with EN 12978.

Example of a typical installation

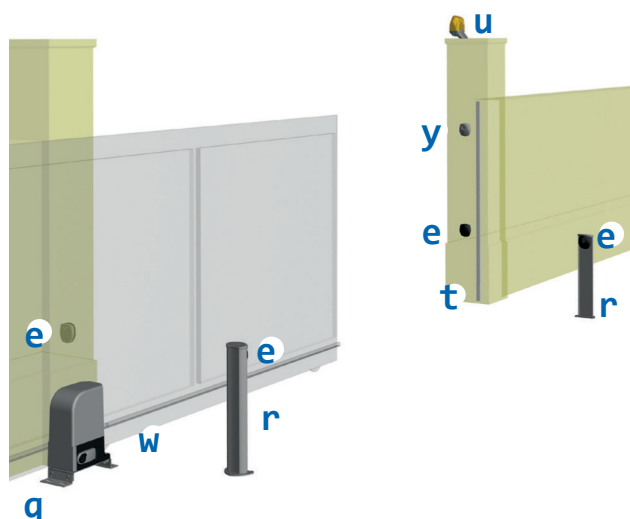

KIT

1

COD. 614700
Art. LIVI 6N
Automation for residential sliding gates

w

COD. 619000
Art. 111
Nylon rack, with fixing screws (1m)

KIT

e

COD. 662080
Art. LINEAR/XS
Pair of mini synchronizable photocell for outdoor installation. Maximum range 20m

r

COD. 664000
Art. PILLY/60
55cm column for photocell (2 pcs)

t

COD. 171035
Art. C-20
Mechanical edge L=2m

y

COD. 663090
Art. GT-KEY
Metal vandal proof keyswitch with two contacts, surface mounted. Supplied with 2 keys.

KIT

COD. 661130
Art. AURA N
LED flashing light, multi-voltage 24AC-DC /120AC/230AC, with integrated antenna 433MHz/868MHz

NEW

KIT

COD. 672645
Art. GTI4
Serialized white 4-channel remote control, 433 MHz, with 3 coding: HCS Rolling-Code, Dip-Switch and new D.A.R.T. coding

KIT for further details on the kits see price list

Specific accessories

COD. 619000
Art. 111
Nylon rack, with fixing screws (1m)

COD. 126001
Art. 112
Galvanized steel rack 22x22mm (1m)

COD. 126000
Art. 113
Galvanized steel rack 30x12mm with zinc-plated spacers and fixing screws (1m)

COD. 619042
Art. 450N
Unlocking device by cable for LIVI/N (4,5m). To be used with BLINDOS

COD. 619012
Art. 460N
Additional fundation plate for LIVI/N

COD. 672920
Art. D-BAND KIT
Wireless transmitter and receiver kit in 868 MHz, for resistive or mechanical safety edges

COD. 171034
Art. C-16
Mechanical edge L=1.6m

COD. 171035
Art. C-20
Mechanical edge L=2m

COD. 171039
Art. CR-20
Resistive edge L=2m

COD. 171040
Art. CR-25
Resistive edge L=2,5m

COD. 171044
Art. CC-20
Conductive edge L=2m

COD. 667053
Art. SOFT3
Safety rubber profile (complete with aluminium base) useful to reduce the impact forces for sliding and swing gates (12m)

COD. 629292
Art. BAT/LIVI/N SUPPORT
Fixing plate for LIVI/N batteries with screws

COD. 665000
Art. BLINDOS
Aluminium safety enclosure, with European cylinder, ready for unlocking device by cable.

COD. 629291
Art. BAT/LIVI 3-6-9/24
Rechargeable batteries kit for 24V operators, 12V - 1,2Ah, complete with wiring cables and fixing plate

Technical info

TECHNICAL INFO	LIVI 403N - LIVI 6N LIVI 6N/M	LIVI 803N - LIVI 9N LIVI 9N/M	LIVI 6/24N/F LIVI 6/24N/M	LIVI 6/24N/F-BOOST LIVI 6/24N/M-BOOST	LIVI 9/24N/F LIVI 9/24N/M
Motor power supply (V)	230V ~ ±10% (50/60 Hz)		24V □		
Maximum power absorption (W)	320	450	80		110
Max thrust (N)	340	490	210	240	260
Duty cycle (cycles/h)*	18	11	22		18
N. max. cycles in 24h*	60	40	60		40
Built-in capacitor (µF)	8	12,5	\		
Operating temperature (°C)	-20 ÷ 50				
Motor thermal protection (°C)	140	160	\		
Speed (m/min)	10			16	10
Standard pinion	Z16	Z16	Z16	Z16	Z16
Weight with packing (Kg)	11	12,5	12		
Sound pressure (dBA)	< 70				
Protection level	IPX4 (IP44 for versions with magnetic limit switches)				

* For a 5m leaf length

Wiring

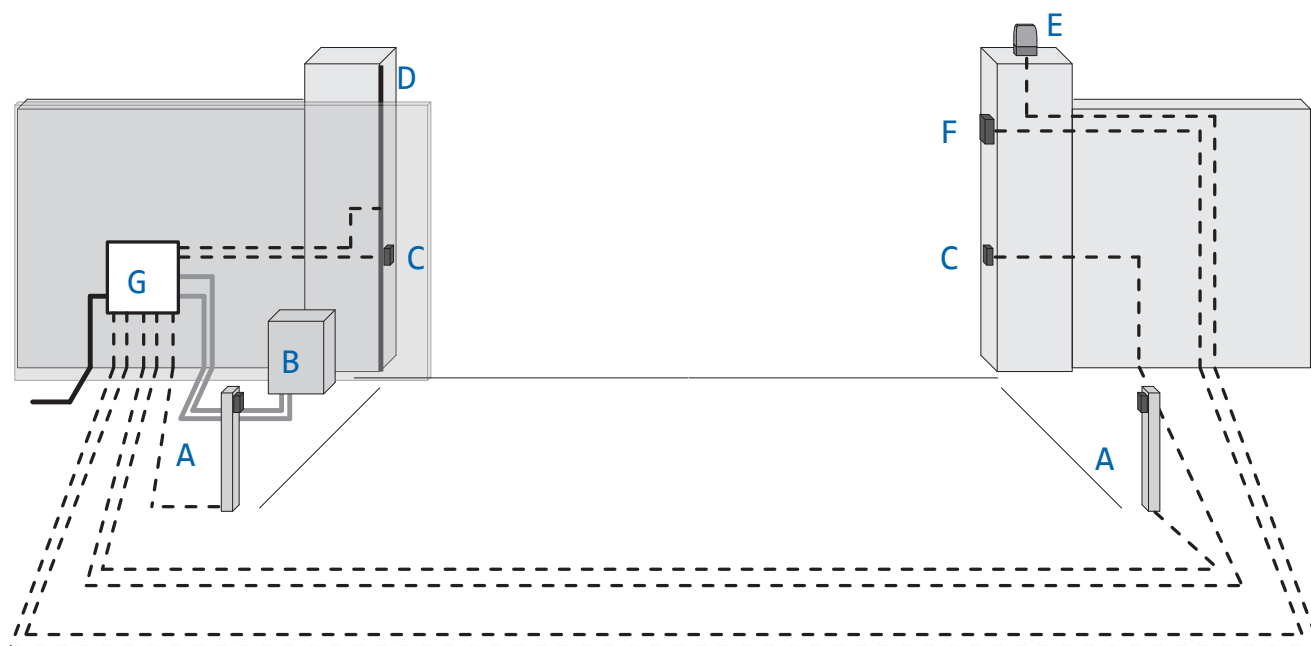

- Corrugated pipe for power supply cable
- Ø40 corrugated pipe for connection between the control board and the junction box
- - - Ø20 corrugated pipe or external PVC conduit for connection between the control board and the command and safety accessories

pos.	description
1	Column with photocell
2	Operator
3	Photocells
4	Safety edge
5	Flashing light
6	Keyswitch / Digikey
7	Junction box

Dimensions

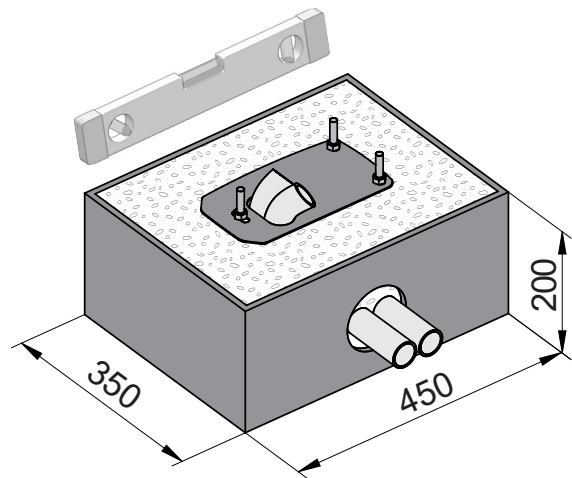
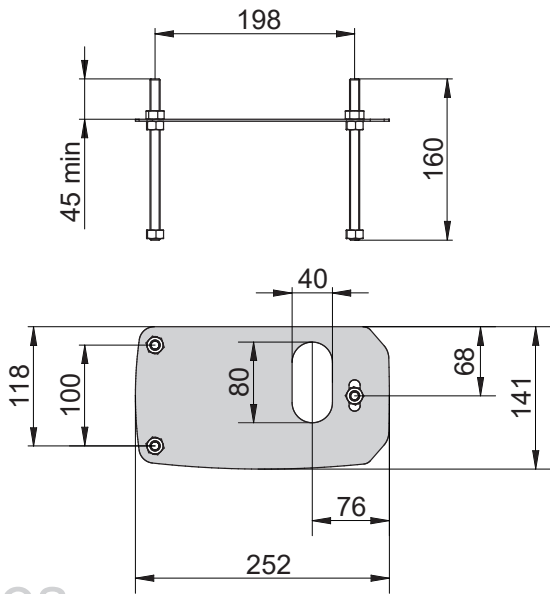
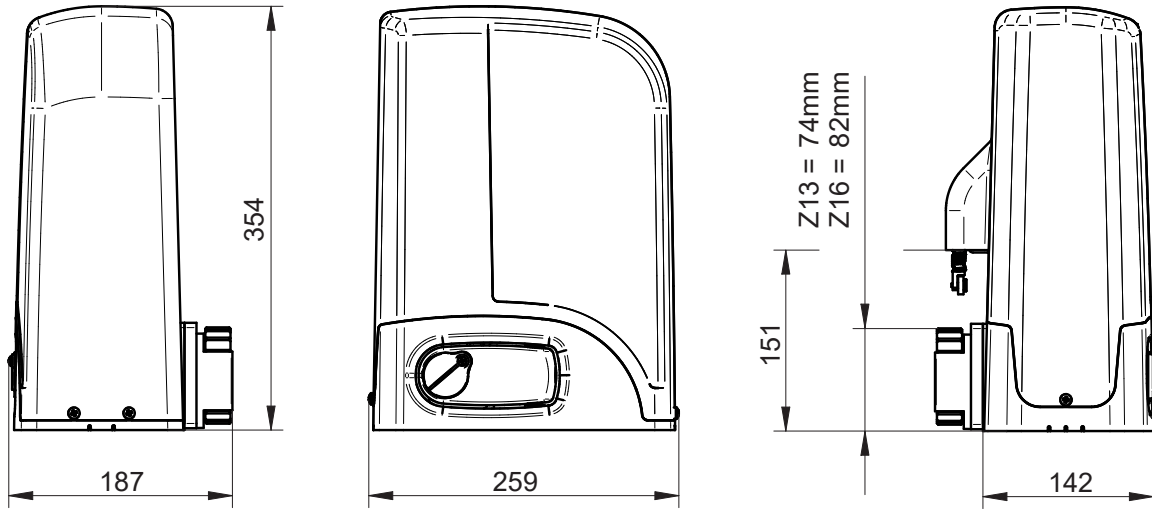

notes



What about the products? We make them ourselves!

We manage the **whole production process**. We design, produce and assemble both the mechanic and electronic components of our products. This is crucial to guarantee the quality of each component, especially when technology is connected to people's safety.

All our products are made with high quality materials, such as steel and bronze, which guarantee reliability over time.

What about electronics? We also make it ourselves.

Each DEA product is **totally** conceived and developed in-house. **DEA HT**, a company that is a part of our group, designs and produces the electronic components controlling our automations.



DEAuser



DEAuser is the app for **private users** that allows activation of automation at **close proximity** via Bluetooth.

By installing the NET-NODE on all devices with NETLINK technology, users can control their automations through their smart devices.

To be used with:



Art.NET-NODE
Cod.677640

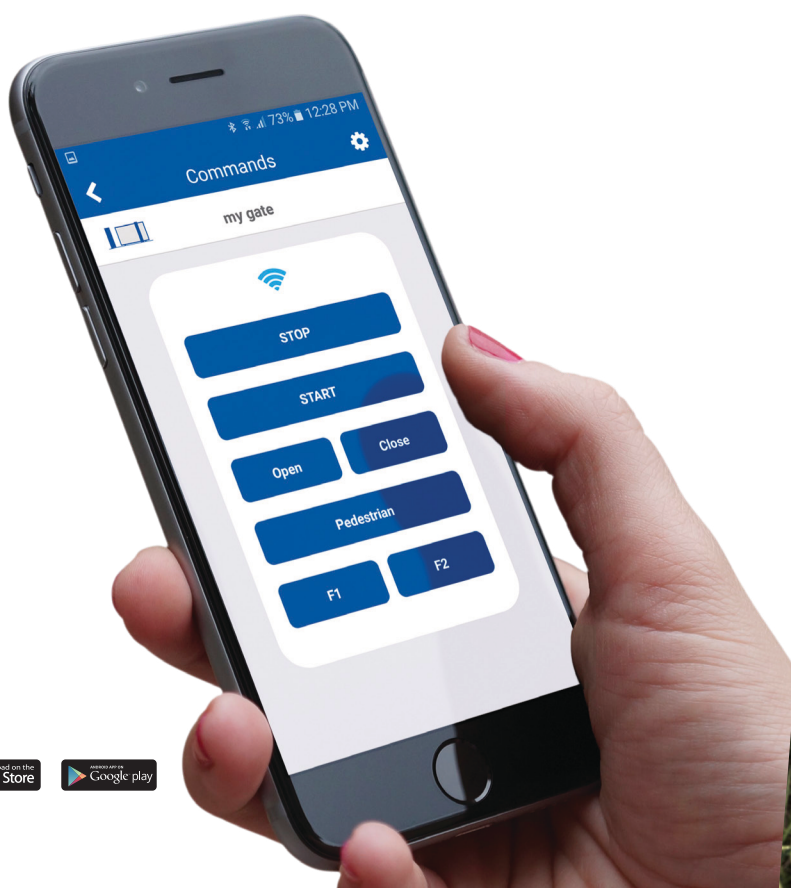

DEAinstaller



DEAinstaller is the App dedicated to the **professional installer** and allows Installers to program and manage DEA automations on-site in a simple and intuitive way from their smart devices.

If you use it with the NET-NODE you can:

- 0 keep a **data backup** of all installations
- 0 easily adjust the **parameters** of control boards
- 0 update the **firmware**
- 0 program the **maintenance**
- 0 manage or customise the **remotes**
- 0 read **technical manuals** or have a look at the **electrical connections**
- 0 control the **inputs** and **output** of the control boards
- 0 **control** the automation with the App

To be used with:



Art.NET-NODE
Cod.677640

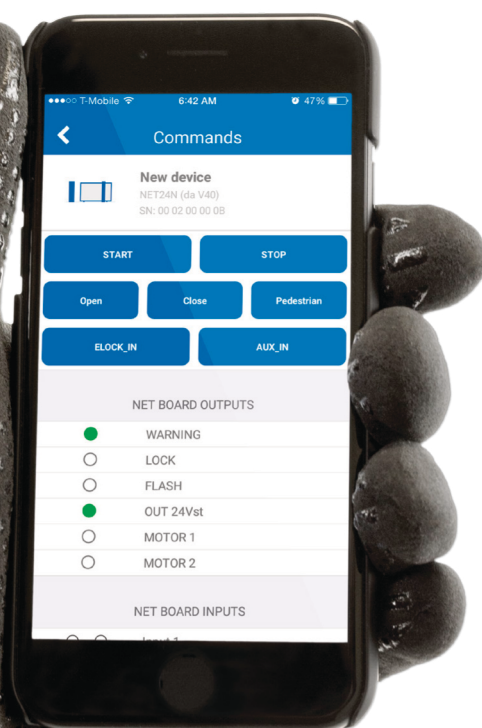

Generic accessories



✓ 24V
✓ 120V
✓ 230V

AURA N

cod. 661130



LINEAR XS

cod. 662080



LINEAR

cod. 662044



COVER/2

cod.681060



LINEAR SHIELD

cod. 662047



PILLY 60 -120

cod. 664000 - 664010



DIGIPRO

cod. 663310



DIGISLIM

cod. 663311



GT-KEY

cod. 663090



DIGIRAD

cod. 663280



BAT/LIVI 3-6-9/24

cod. 629291



GTI2-GTI4

cod. 672635 - 672645



GTI2M-GTI4M

cod. 672603 - 672613



BLINDOS

cod. 665000

#safeasyoulike!

Non-copyable remotes!

GTI remotes are multi-function. They have three coding possibilities: DIP SWITCH, Rolling Code and D.A.R.T. the new DEA advanced coding.

You can customise the code of the remotes to guarantee the maximum security to your customer.

D. DEA
A. Advanced
R. Rolling Code
T. Transmission

Looking for **total safety**?
With **NET-BOX** each installer can customise the code of your GTI remotes.



#colourasyoulike!

Choose your favorite colour!

GTI remotes can be customised with button kits in seven colours: green, light green, blue, pink, yellow, orange and purple.



Note: button kits are supplied in packs of 5. The remote must be ordered separately.



NETLINK

is our technology applied to DEA devices for the smart management of your installations, both **locally** and **remotely**.

DE@NET

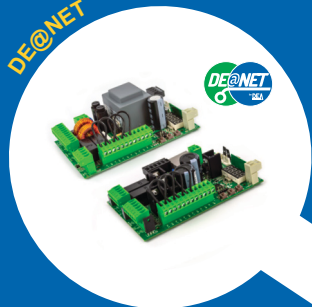

One control board for all our motors, available in 230V and 24V versions.

NET-COM



The device for the managing installations remotely.

NET-NODE



The device for managing installations locally.

NET-BOX



The device for managing remotes from your office.

DEA User & DEA Installer



DEAinstaller:
the App for creating and managing each installation directly from your smartphone.



DEAuser:
the App for opening and closing your DEA gate with just one touch, locally.

Our range

Automations for sliding gates



Automations for sectional doors



Automations for swing gates



Automations for industrial gates



Barriers



Bollards

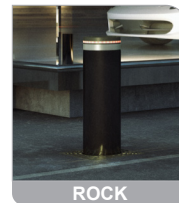

DEA[®]
move as you like

VSH TECHNOLOGY SDN. BHD. (1324705-P)

93, Jalan BP 7/2, Bandar Bukit Puchong, 47120 Puchong, Selangor.

Hotline: +6 019-348 1168 : +6 013-234 6281

Office Line: +6 03-8066 8482 : +6 6080 2818

Email: sales@vshgroup.com.my Website: www.vshgroup.com.my