

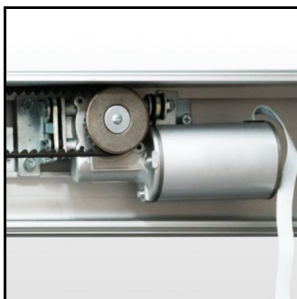

Ranger automatic sliding door operator are easy installed, durable, reliable performance, safe and low noise operation. You can transform your any door rapidly into an automatic sliding door without complication. Range automatic sliding door operator also able to increase convenience and provide barrier-free access for the disabled too.

Ranger automatic sliding door operator highly recommend for application at your living space, working environment etc to make your place more securely.



Brushless Motor

Adopting brushless motor with a long service life & larger torque.

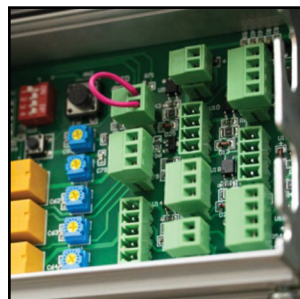

Built-in Control Unit

Easy adjust sliding door precision move according door size & weight.

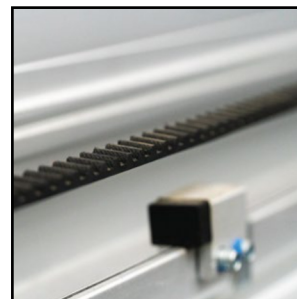

Reliability

High reliability synchronous belt, drive door forward and backward with help of hanger.

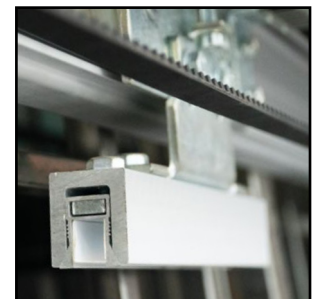

Stable

Adjustable door hanger and clamp type door support even heavier glass door with smooth operation on the railway.





Motor Lock Function

Motor lock function with no additional electric lock is required. When the power is off, the automatic door will hold open and win the escape time.



Self-Checking Function

Every time the machine turned on, the door will rebound when it encounters obstacles, which fully guarantees the safety of passing personnel.

150 ^{KG}

Maximum Door Weight

Maximum support door weight up to 150KG.

*All image and specification is subject to change without prior notice.

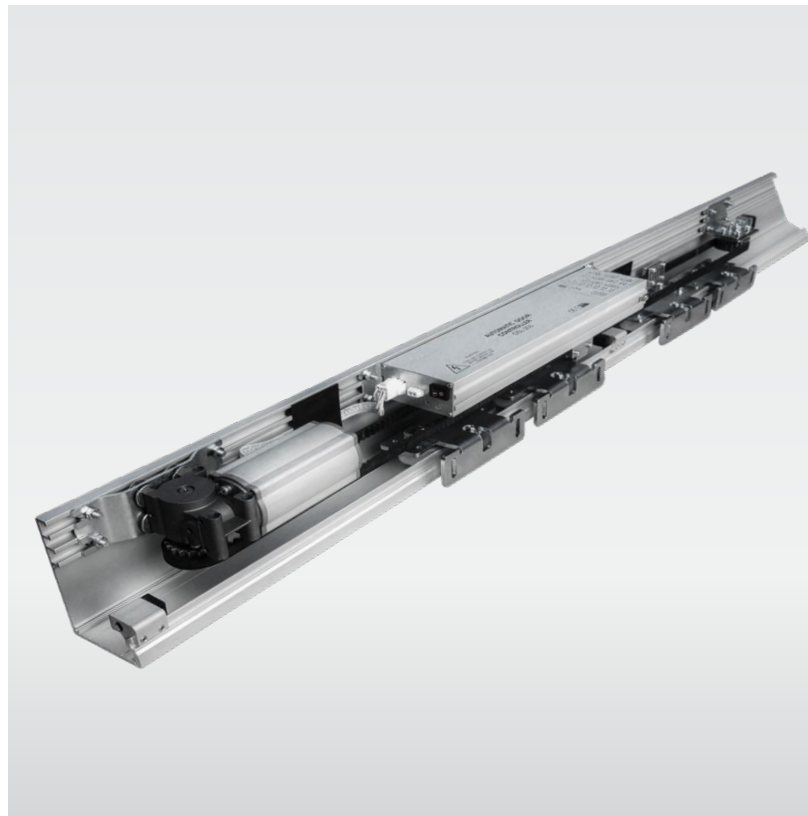

Technical Data	RG-AT120D-L-4	RG-AT120D-L-5
Length of Rail	4.2M	5.0M
Door Configuration	Single /	Double
Door Leaf Weight	≤ 1 x 150KG	≤ 2 x 120KG
Clean Open Width	600~1800mm	1000~3000mm
Manual Push	<30N	<40N
Power Voltage	AC220V	
Frequency	50-60Hz	
Opening Speed	200~500mm/s(Adjustable)	
Closing Speed	200~500mm/s(Adjustable)	
Hold Open Time	0~9s(Adjustable)	
Power Consumption	70W	
Sliding Noise	≤55dB	
Environment Temp.	-20°C ~ +50°C	

Standard Colours

White Aluminium
(Similar to RAL9003)

Ordering Info

Model	Door Configuration
RG-AT120D-L-4	Single / Double Door
RG-AT120D-L-5	Single / Double Door

RGAT120DL 425M,SINGLEDDOUBLEDOOR





Wireless Push Button

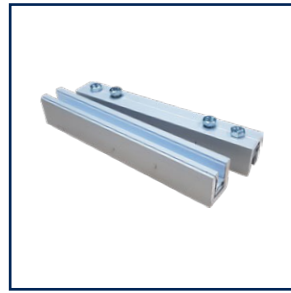

Glass Clamp



Safety Beam Sensor



Key Switch

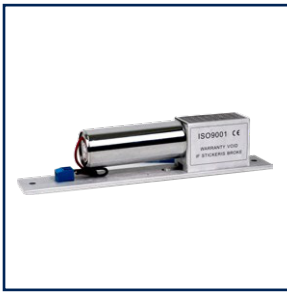

Drop Bolt Lock



Battery Pack

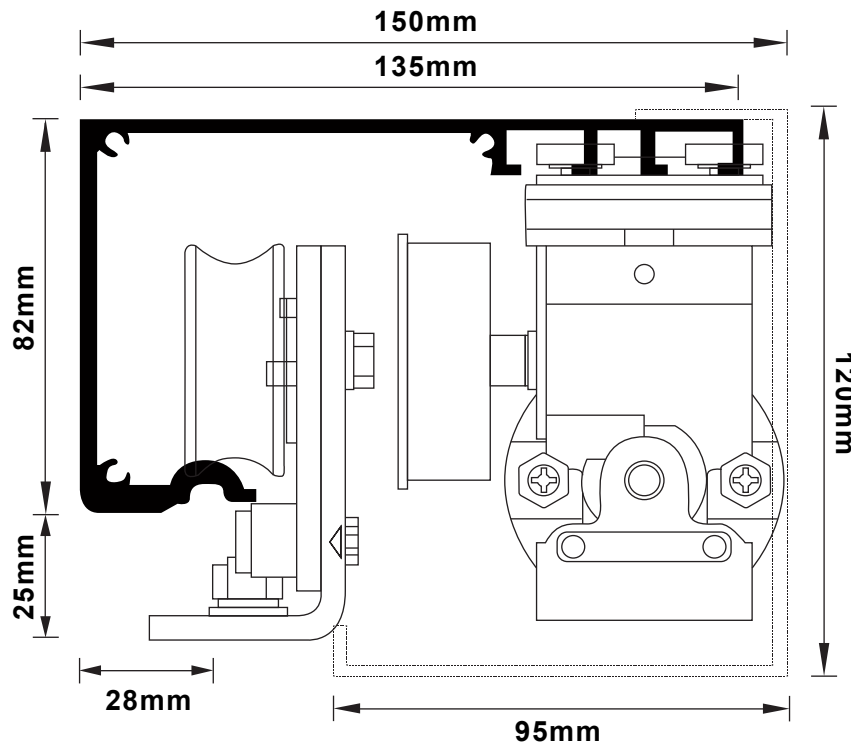

Office Line
+6 03-8066 8482
+6 03-8060 2818



Hot Line
+6 019-348 1168
+6 013-234 6821



Email
sales@vshgroup.com.my



Address
No.93, Jalan BP 7/2, Bandar Bukit
Puchong, 47120 Puchong, Selangor.



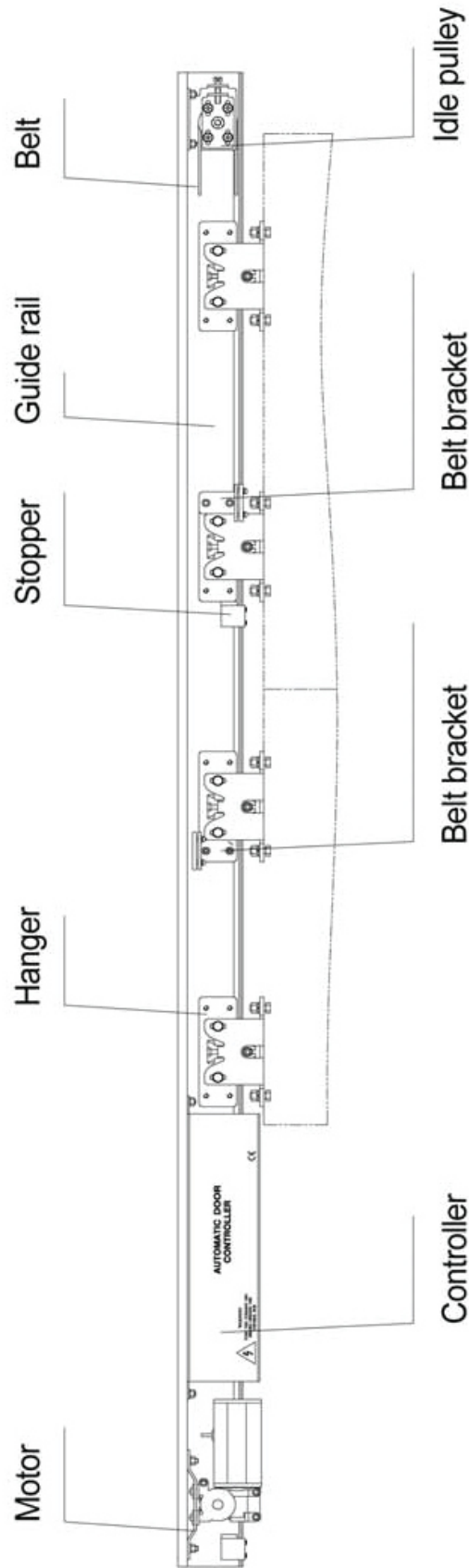

Office Line
+6 03-8066 8482
+6 03-8060 2818



Hot Line
+6 019-348 1168
+6 013-234 6821



Email
sales@vshgroup.com.my



Address
No.93, Jalan BP 7/2, Bandar Bukit
Puchong, 47120 Puchong, Selangor.

