

VS-T2000WP TRIPOD TURNSTILE



Two Lane



Single Lane

Functions & Features

- Reasonable and reliable design, low noise, smooth operation and long service life.
- Equipped with power-off and pole dropping function, remote control can be added for pole dropping control
- LED indicator, valid card showing green, illegal card showing red
- Card can be set "with memory" or "without memory"
- With automatic reset function, i.e after having access to the gate, the gate automatically restores to the locked state if not pass within the time set
- Compatible with IC, ID card, scanning and face recognition
- With unified and standard external electrical interface to facilitate system integration
- Extensible to realize access control, attendance, fees and other function
- Can be used outdoor completely, one machine can be use as a lane

Application Scenarios



School



Museum



Factory



Gym

Technical Parameter

Parameter	
Size (L*W*H)	1400*280*980mm
Pass width	550mm
Power	35W
Material	δ=1.5mm SUS304
Bar Material	SUS201
Movement	Semi-Auto tripod turnstile movement with anti-pass back function
Indicator Light	RGB light+Dynamic indicator light
Power Supply	24V 50W
Control Unit	Main board
Communication Interface	Dry contact/ RS485
Pass rate	35-50 persons/minute
Temperature	-20°C~+70°C
Humidity	≤90% No condensation
Environment	Indoor and outdoor
Level Protection	IP54

Dimension Diagram

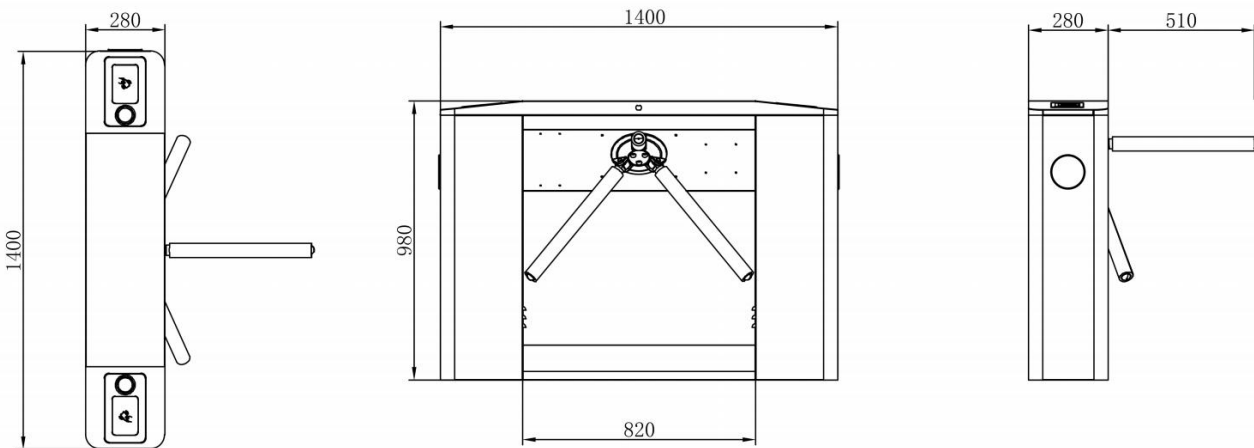

Case Share

