

TS2000 Plus Series

Drop arm tripod turnstile.
Improve the turnstile reliability and efficiency.



Introduction

ZKTeco's TS2000 Plus series is a bridge type tripod turnstile. This tripod turnstile's cabinet using SUS304 stainless steel, ensuring long durability. TS2000 Plus offer an aesthetically verification area for user, with a streamlined under mount RFID card and QRcode reader. The turnstile not only have efficiently people flowing control and also providing safety function such as automatically drop arm if power off or emergency signal input. The tripod arm can set bi-directional movement as a standard function. Also, users can set the tripod arm in a different working mode by direction All in all this tripod turnstile is very easy to be setting up for most kind of indoor or outdoor situations, such as schools, museums, factories, gyms, etc.



Access Control System

There are multi different access solution owned by ZKTeco, including RFID and biometric technology or QR code verification. Also allow customer to install third-party systems.

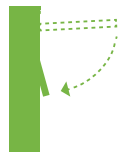

Drop-arm

Safety function always standby, turnstile drop arm automatically. It making sure people exit easily during power off, emergency case like fire case happening.



Bi-directional

The turnstile enable to be setting as different pass mode, like one way free, one way standard. Also the device memory mode allow group user pass-through.

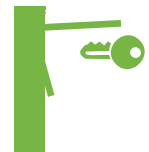

Security Key Unlock

With security key easily to access turnstile inside. It will let installer or administrator will feel convenience operation&maintenance device.

Key Features

Durable

SUS304 stainless steel housing making sure the device have good ability for anti-rust. Certified by Salt spray test 72 hours.



Arm loading

The stainless steel arm with 38mm diameter of rod. It provides maximum 40Kg weight loading of vertical direction at end of arm.



A built-in LED indicator Lights

A built-in LED indicator is present in the identity authentication area. The green indicator represents that you can pass through, while the red indicator shows that you cannot pass in the opposite direction.



Protection disk

The purpose of a protective disc is to safeguard the device against dust, corrosive water vapor, or splashing water, thereby enhancing the durability of the device and reducing maintenance frequency.

Waterproof

Passed the self-laboratory test which is equivalent to IPX4 protection rating.

Easy to set up

Simply design and easy access construction of device, drawing very low power.



Specifications

Model	TS2000 Plus Series
Visual Indicator	Steady Green = Normal Use Steady Red = Door closed
Audio Indicator	Internal Buzzer
Lane Type	Single Lane
Lane Width	550mm
Barrier Movement Type	Rotating
Lid Material	SUS304 Stainless Steel
Lid Options Authentication Methods	KR800E Reader, FR1500SReader
Chassis Material	SUS304 Stainless Steel (T=1.2mm)
Chassis Color	Silver-gray
Door Leaf Material	SUS304 Stainless Steel
Motherboard Function	Door Open Duration, Access Mode
Motherboard Communication	Fire Alarm Port (Relay)*1, RS485 port *1
Controller	Options: C3-200, InBio 260 Pro or third-party devices
Credential Options	Under Mount RFID Reader: (Support Model: Pro ID Series, KRSeries) Under Mount Fingerprint Reader: FR1200 / FR1500
Flow Rate	25 Passengers per minute
Footprint	260*1110 (mm)
Accessibility	Wireless Remote Control, Wired Remote Control, QRreader
Power Supply	110V / 220V AC@50 to 60 Hz, DC 12V
Power Rating	10V A (Standby) 40VA (Operation)
Fire Signal	Input for Voltage Free Contact
Noise Level	<65dB
MTTR	Less than 60 minutes
MCBF	2 Million
Weight	30kg
Dimension	775*1100*980 (L*W*H) (mm)
Operating Temperature	-20°C to 70°C
Operating Humidity	20% to 80% RH (Non-condensing)
Certifications	CE, FCC, UKCA (pending), ISO 9001
Ingress Protection Rating	IPX4
Supported Software	ZKBio CVSecurity (Compatible with software only when connected to the control panel)
Safety Features	Voltage Free Contact Input for Fire Alarm Fail State Automatic drop arm during power off
Security Features	Anti-tailgating
Product Delivery	Pre-assembled

Application Environment	Indoor/Outdoor (If sheltered)
Site Preparation	Flat & Level Finished Floor (Base Plate in options for unfinished Floor)
LED Indicator	Support
Optional Accessories	Counter, SUS316 Cabinet and Lid, Remote Control
Dimensions With Packing	360*1210*1080 (L*W*H)(mm)
Weight With Packing	35kg
Cabinet Material	SUS304 Stainless Steel (T=1.2mm)
Security Level	Medium
Emergency Mode	Support

Dimensions (mm)

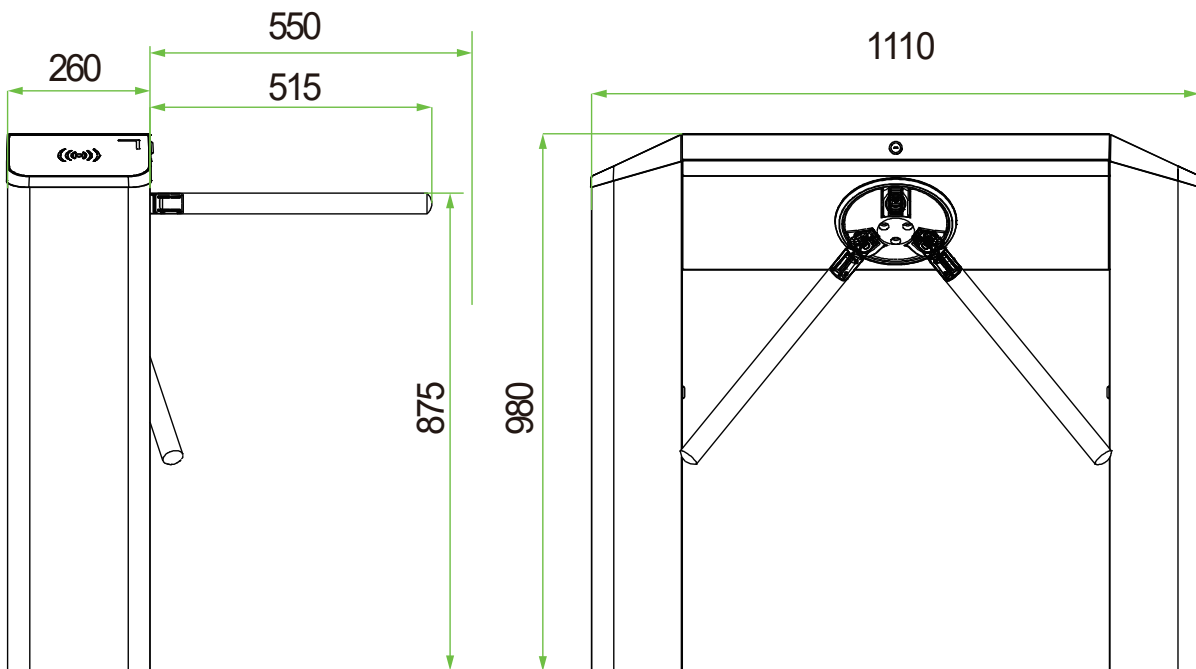

Application Scenarios



School



Museum



Factory



Gym



Email: sales@vshgroup.com.my

Website: www.vshgroup.com

Tel: +603-8066 8482

Hot Line: +6019-348 1168

