



CMP200-90D

Automatic Barrier Gate with Telescopic Boom Arm

The CMP200 series offers brand-new automatic barrier gates equipped with telescopic boom arm that allows direction exchanging according to site application and a silvery housing with built-in LED indicating the state of the parking barrier, providing humanized user experience. Its appearance and structure are designed based on the feedback and needs of the market and industry. Comparing with other barrier gates, the CMP200 series of automatic barrier gate products with telescopic straight boom might be an economic good fit meeting demands in different parking lots.

Features

- Better experience with auxiliary traffic lights in the main body
- Support anti-smash and automatic closing with an infrared detector, loop detector, radar detector
- Arm direction can be exchanged between leftward and rightward according to site application
- Opening and closing angle of $90^{\circ} \pm 2^{\circ}$
- Over voltage protection
- Support LPR, UHF reader controller and other devices for recognition and other A&C functions

Specifications

Gate Opening / Closing Time	3s (max. 4.5m), 6s (max. 6m)	Working Temperature Range	-25°C~ +75°C
Supply Voltage	AC110V/220V, 50/60Hz	Working Humidity Range	≤90%
Power Consumption	100W (max. 120W)	Housing Dimensions (D*W*H)	350 * 280 * 1010 (mm)
Remote Controlling Distance	≤30m	Packing Dimensions (D*W*H)	420 * 405 * 1100 (mm)
Remote Controlling Frequency	430MHz	Net Weight	45kg
Cabinet Material	Cold rolled steel	Gross Weight	47kg
Boom Material	Aluminum and wood		
Motor MCBF	1 million times		

Boom Information

Boom Type	Telescopic boom	Straight boom with LED	Folding boom
Boom Length	4.5m (packaging length 2.8m), 6m (packaging length 3.6m)	Max 4.5m	Max 4m
Opening / Closing Time	3s (max 4.5m), 6s (max 6m)	3s	3s

Product Details

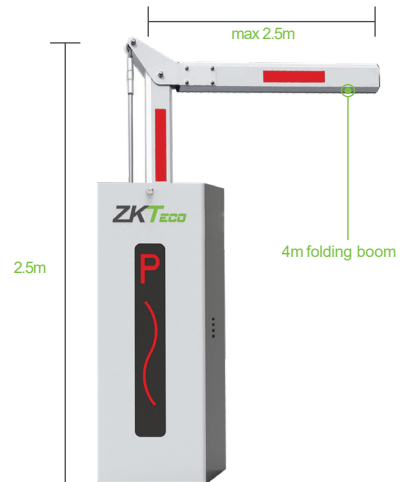
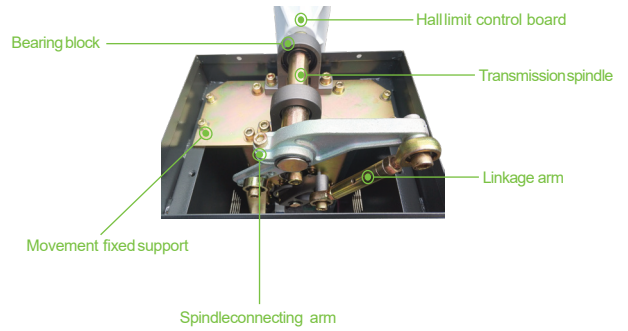
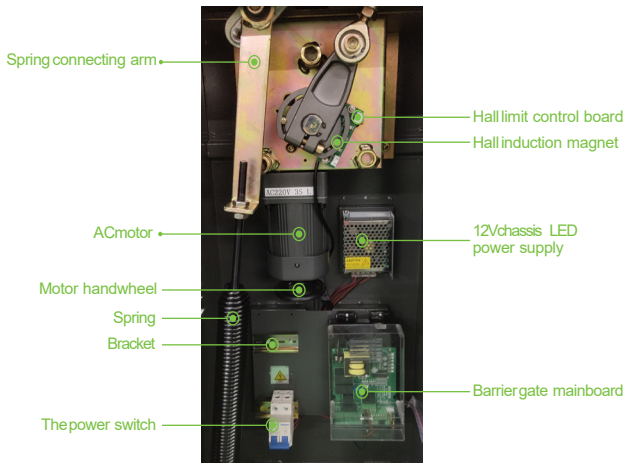
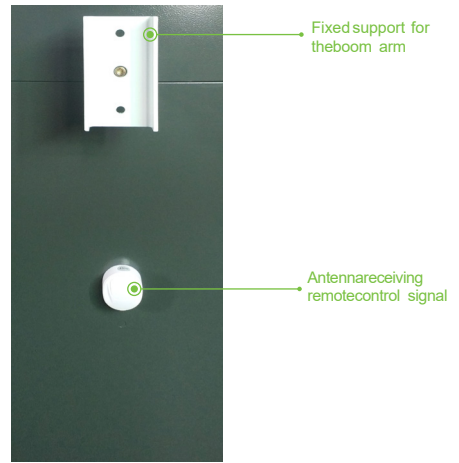

Dimensions (mm)

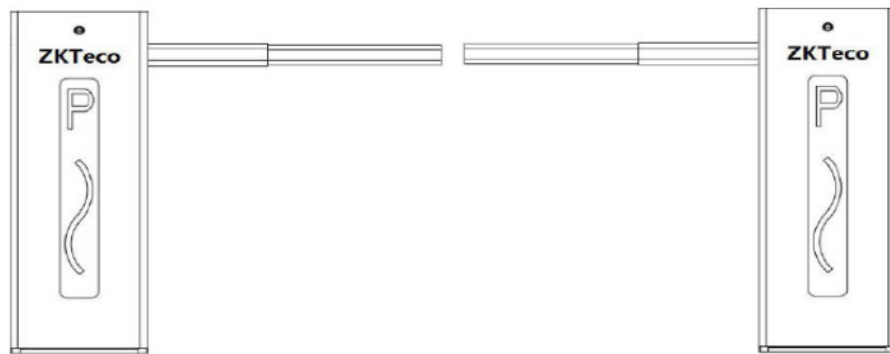
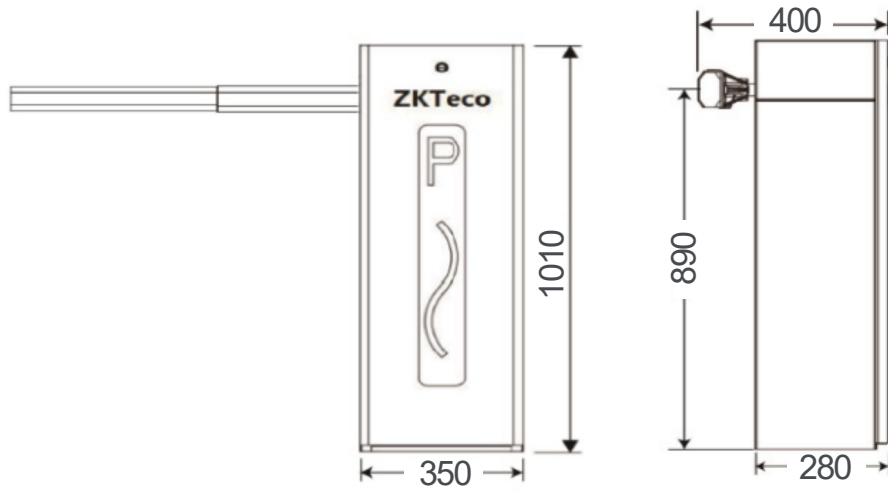

Left fixed: The cabinet on the left

Right fixed: The cabinet on the right

